

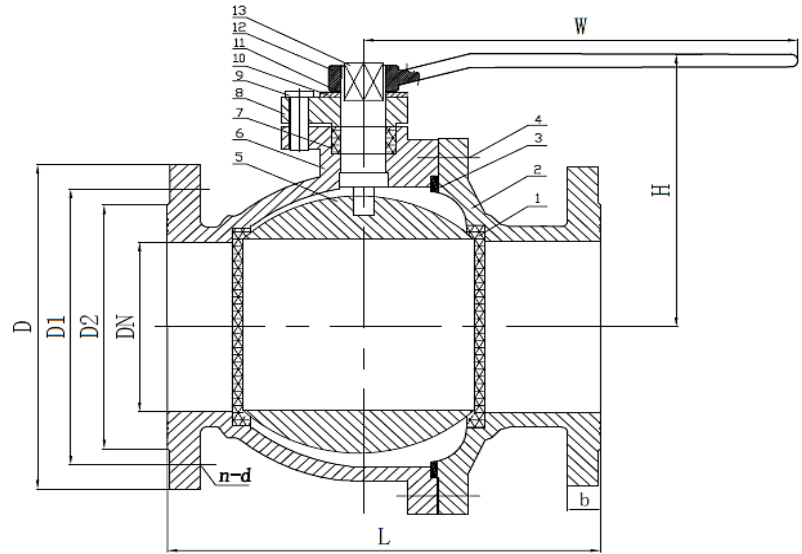

CAST IRON BALL VALVE

Model: B01.0201



SPECIFICATION

DESIGN	2-Piece Body, Full Bore
PRESSURE RATING	10 Bar
WORKING TEMPERATURE	-45°C ~ 180°C
OPERATOR	Lever/ Worm Gear
CONNECTION	Flange End Drilled to JIS 10K/ ANSI 150 B 16.5

MATERIAL

Item	Name	Material	Item	Name	Material
1.	Washer	PTFE	8.	Gland	GGG50
2.	Bonnet	GGG50	9.	Bolt	40Cr
3.	Graphite Gasket	Graphite	10.	Locking Washer	Galvanized Iron
4.	Bolt	40Cr	11.	Locking Ring	Manganese Steel
5.	Ball	SS210	12.	Wrench	GGG50
6.	Body	GGG50	13.	Lever	2Cr13
7.	Washer	PTFE			

DIMENSION

DN	15	20	25	32	40	50	65	80	100	125	150	200
L	108	117	127	140	165	178	190	203	229	356	394	457
H	78	113	107	113	130	146	176	222	222	250	275	487
W	135	135	150	175	200	245	270	300	320	350	650	800
D	95	100	125	135	140	155	175	185	210	250	280	330
D1	70	75	90	100	105	120	140	150	175	210	240	290
D2	52	58	70	80	85	100	120	130	155	185	215	265
B	12	14	14	16	16	16	18	18	18	20	22	28.5
n-d	4-Ø15	4-Ø15	4-Ø19	4-Ø19	4-Ø19	4-Ø19	4-Ø19	8-Ø19	8-Ø19	8-Ø23	8-Ø23	8-Ø23